

shower *PLAY* ces

pr1mus easy board



pr1mus easy board flat



pr1mus easy board line

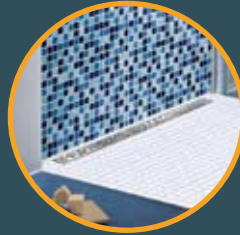



pr1mus easy line





shower **PLAY**ces

content	page 3	
products		
overview	page 5	
pr1mus easy board	page 6	
pr1mus easy board flat	page 8	
pr1mus easy board line	page 10	
pr1mus easy line	page 12	
models & dimensions	page 14	
pr1mus		
philosophy	page 18	
contact	page 19	

the love of **freedom** connects people...



quality and spirit of the age

overview

pr1mus showerPLAYces

provides the basis for a showering experience without limits

shower board systems with concentrated drainage

pr1mus easy board

pr1mus easy board flat

shower board systems with line drainage

pr1mus easy board line

line drainage systems

pr1mus easy line

shower systems that are floor-level and thus barrier-free open a new feeling of freedom to you thanks to the omission of standardised limitations

innovative, exclusive, creative

future-orientated systems, which correspond to your lifestyle

the contemporary design, elegant aesthetics and the virtually unlimited structuring possibilities of our showerPLAYces products shape modern bathrooms and bring the idea of a daily wellness experience into reach

unlimited scope

- for private bathrooms at home
- for hotels, wellness and spa areas
- for sport and leisure centres
- for schools, hospitals and nursing homes

naturally pr1mus

with our services on an international level we make no compromises when it comes to quality

- we go into detail

and of course our showerPLAYces products are guaranteed to meet all modern safety und functionality requirements

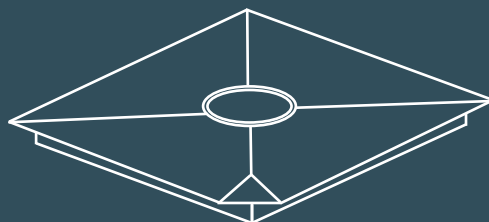
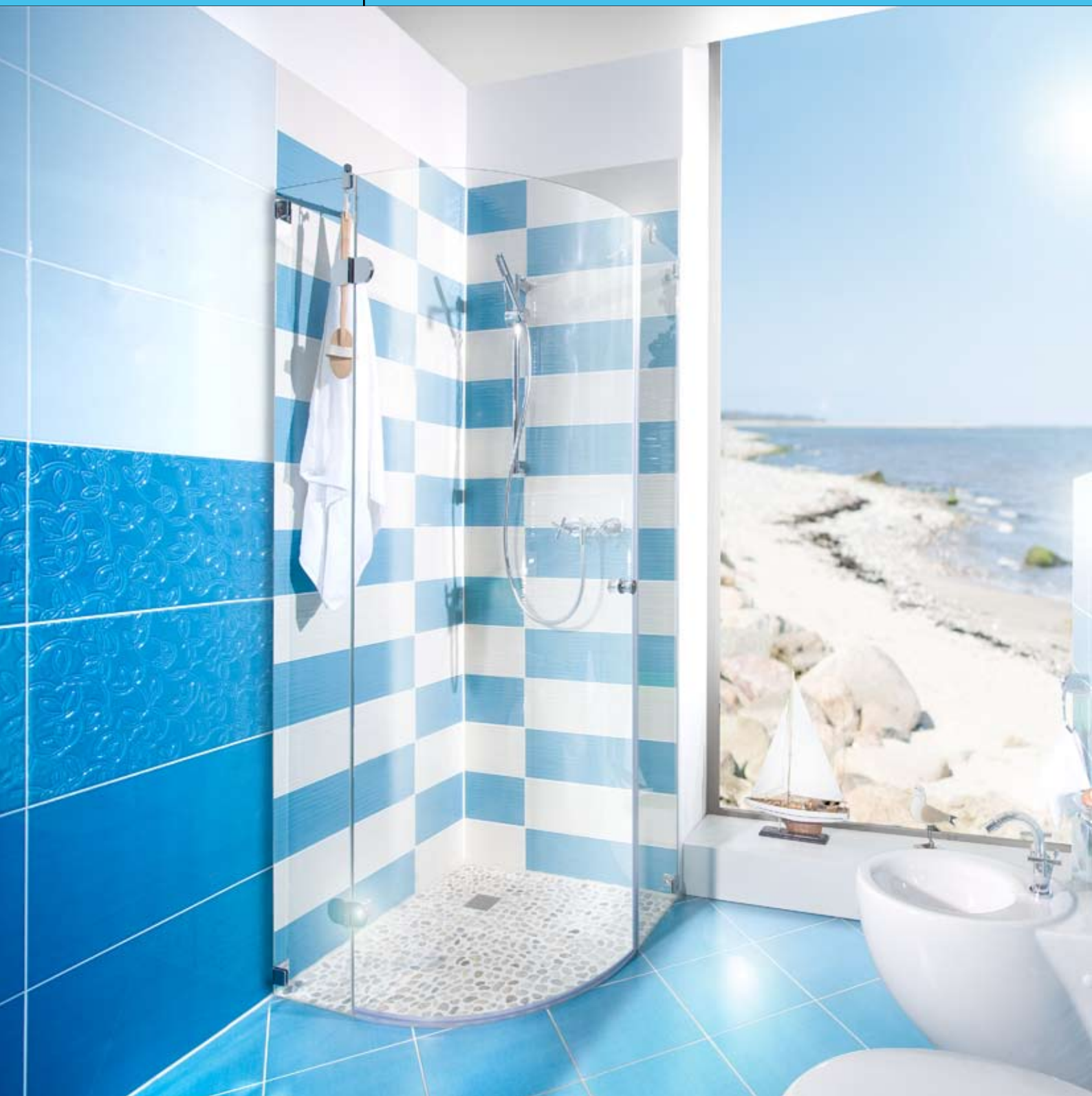

primus easy board

primus easy board

the board - revolutionary and safe

- a patented and entirely prefabricated system from one single source
- extremely high strength: density of approx. 100 kg/m³
- unique wheelchair accessible starting from 2 x 2 cm mosaic edge length with high stability
no problem with concentrated loads
- fitting and tiling in only one day
the interface between tiler and plumber is eliminated
- material and wage savings
sealing membrane already pre-fitted, which ensures a tight connection thanks to its 70 mm wide overlapping
- slope of approx. 2% which is already integrated independent from the board size

drainage - high performance and flexibility

- high drainage rate of up to 1.0 l/s in accordance with DIN EN 274
- adaptable tiling pattern thanks to height adjustable and pivotable drain with stainless steel grid that can be turned 360°
- drainage flange already fitted at the works
- revamp set for the vertical drain

fitting - quick, safe and simple

- one of the lowest installation heights on the market including drainage unit (horizontal) starting from 104 mm
- the nonwoven fabric lining of the primus easy sealing membrane offers a first-class tiling surface
- a virtually unlimited number of ways to create your individual showering experience

products

product example primus easy board 900 x 900 mm

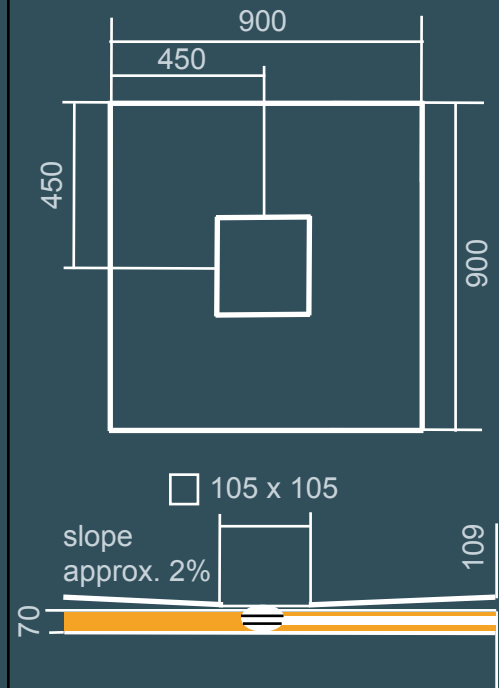

installation

1. foundation element

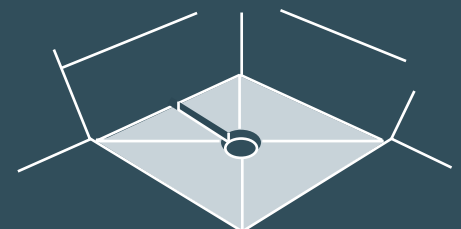

2. drainage

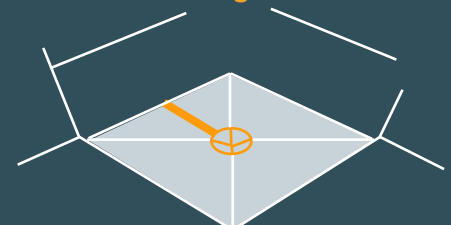

3. primus easy board

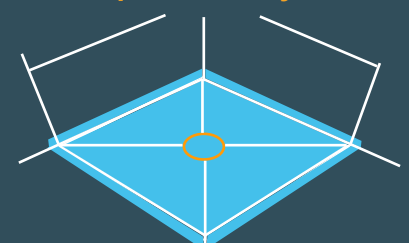

almost like a **day at the seaside...**

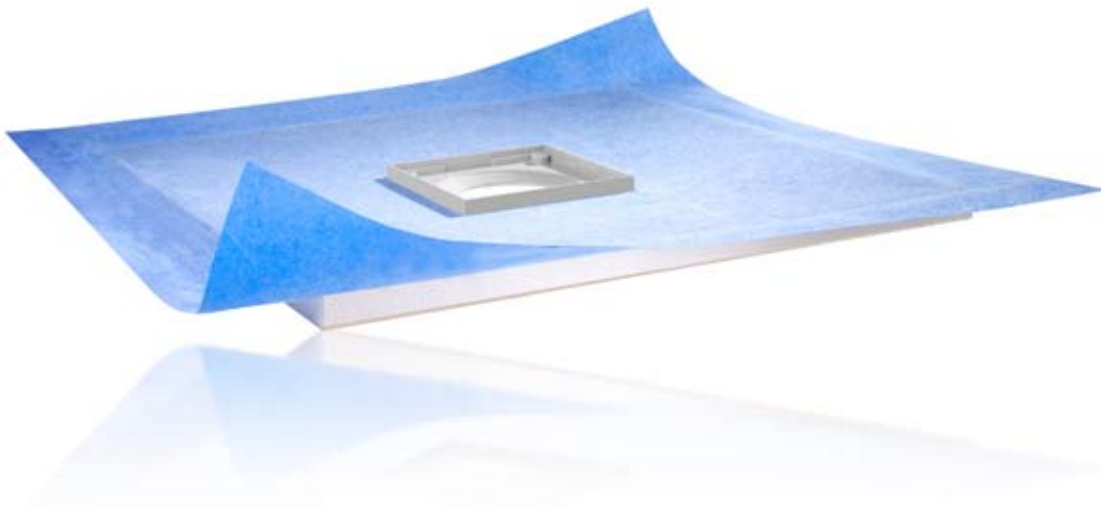

pr1mus easy board flat

height: 18 mm

shell

height: 18 mm

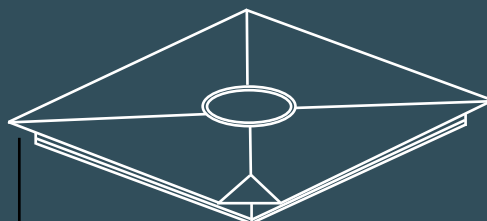

pr1mus easy board flat

products

pr1mus easy board flat

extra flat and mega unique

- our tried and tested pr1mus easy board as an ultra-flat pr1mus easy board flat
- extremely flat
installation height already from 18 mm
- exclusively made by pr1mus
high rigidity with astonishingly small installation height

superior and visionary

- perfect conditions for use with wood construction
- easily adapted to the woodwork layout of floors thanks to off-centre drainage
- can be directly installed into dry floor screed (e.g. chipboard or blockboard), therefore no interfering with the structural mechanics
- also ideally suited for installation in prefabricated houses as well as in reconstruction and renovation

► soon available

product example pr1mus easy board flat 900 x 1400 mm

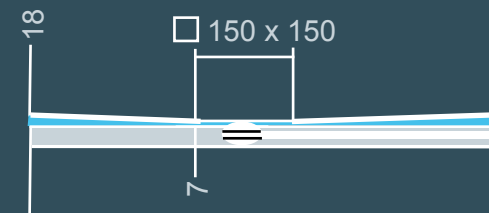
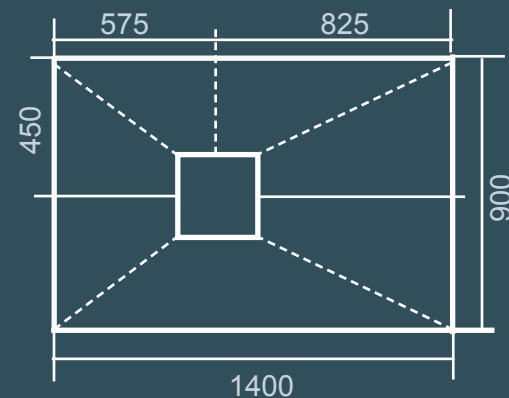

installation in woodwork flooring

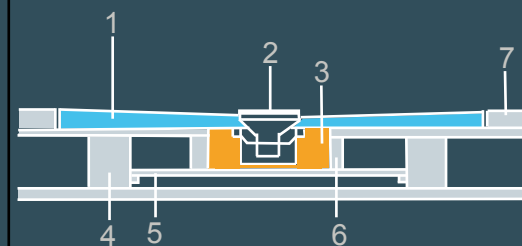

1. pr1mus easy board flat
2. drainage
3. screed
4. joists
5. chipboard
6. formwork element
7. woodwork flooring 18 mm

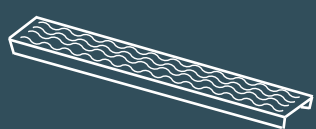
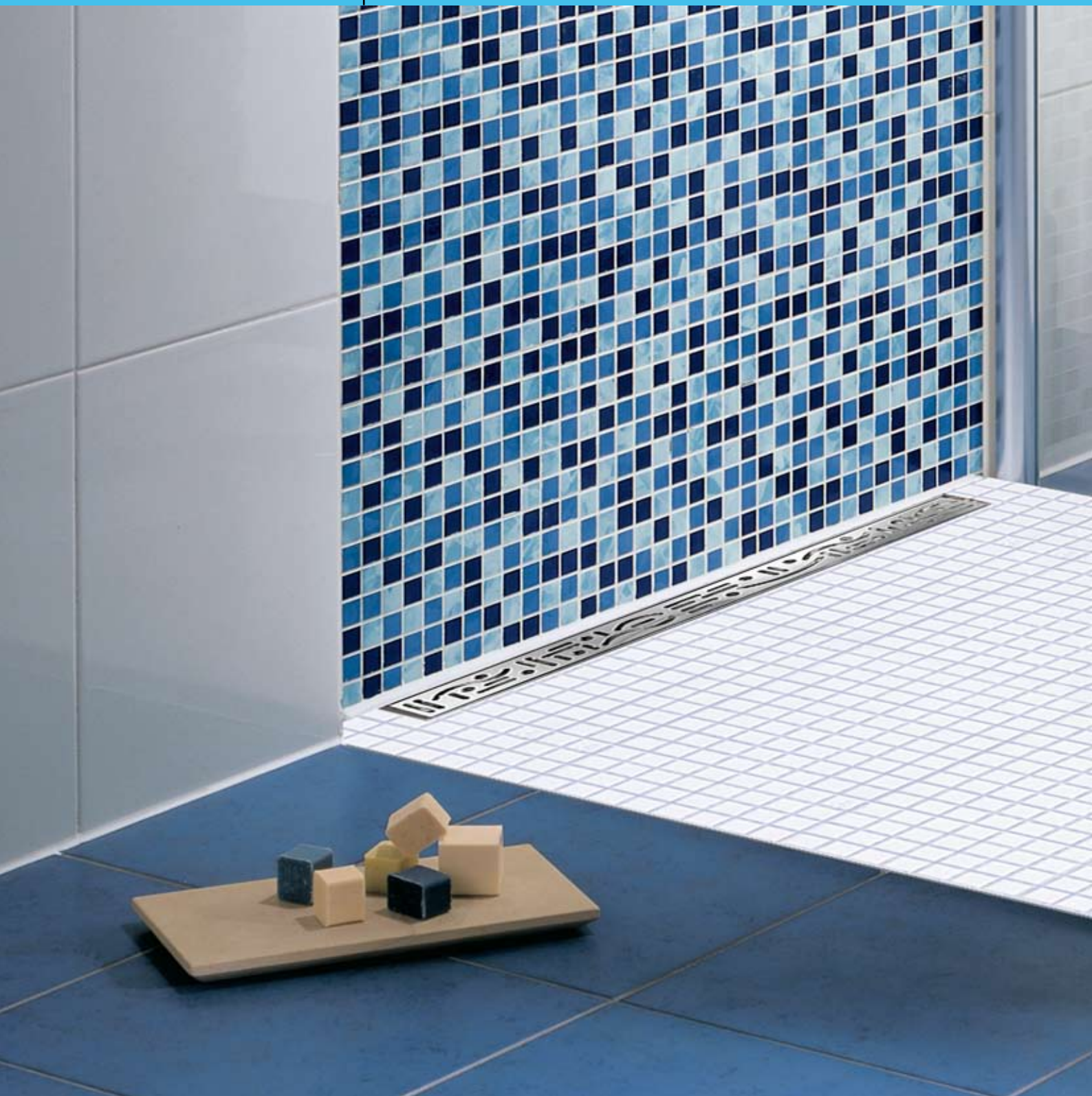

pr1mus easy board line

pr1mus easy board line

synergy of aesthetics and function

- brings together all the advantages of pr1mus easy board and pr1mus easy line
- floor-level shower board with built-in line drainage system
- forms an optical unit over the entire floor
- high drainage rate of up to 0.8 l/s
- smaller slope than with axial and central drainage
- absence of obstacles means more freedom of movement
- in several trendy designs

ingeniously simple - simply ingenious

- simple, safe and quick set-up
- built-in slope
- high strength: density of 60 kg/m³
- slope on one side or on four sides
- the pre-fitted pr1mus sealing membrane with 70 mm overlapping means that additional sealing tape is unnecessary
- horizontal drainage DN 50 0.65 l/s (water seal height of 25 mm)
- horizontal drainage DN 50 80 l/s (water seal height of 50 mm)
- small installation height - 120 or 140 mm plus bonding
- including drainage and foundation element

products

product example
pr1mus easy board line
1000 x 1000
slope on four sides

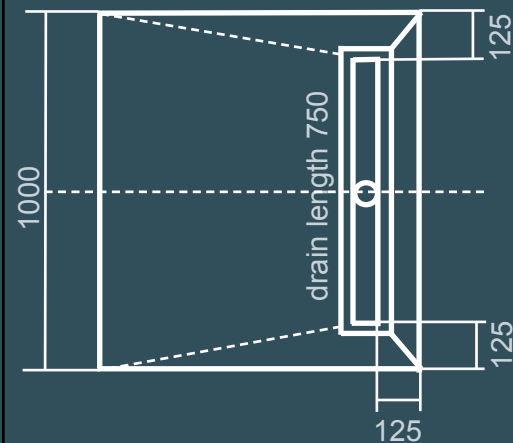

foundation element
h 70 and 20 mm
built-in line drainage

product example
pr1mus easy board line
1000 x 1000
slope on one side

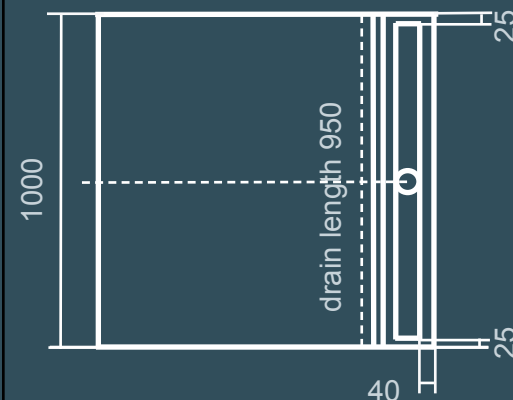

foundation element
h 70 and 20 mm
built-in line drainage

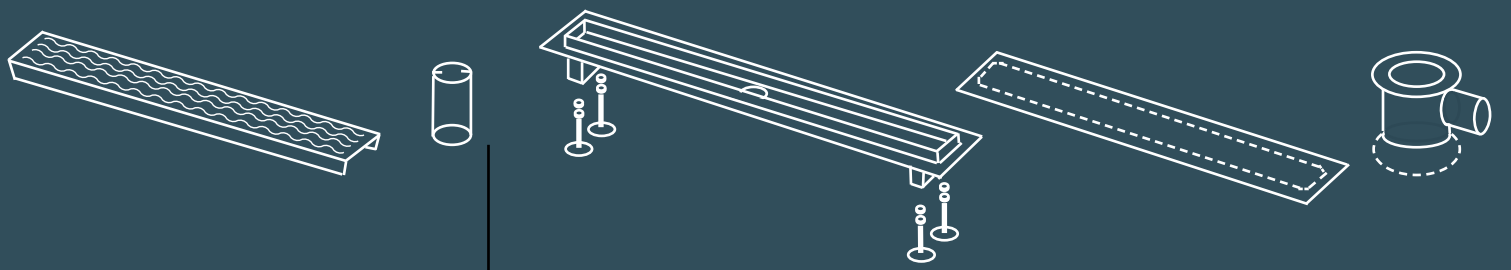

primus easy line

products

pr1mus easy line

contemporary and exclusive

- our solution for line drainage and groundbreaking design
- stainless steel design grids add a nice touch
- the tile grate completes the whole floor area

impressive functionality

- high drainage rate of up to 1.2 l/s
- smaller slope than with axial and central drainage
- absence of obstacles means more freedom of movement
- ground level showering without the need for diagonal tile cuts
- very low installation height of 95 mm
- simple and secure installation thanks to sound-insulating and adjustable mounting feet
- direct and secure sealing thanks to gluing of the flange and the accompanying sealing cuff already welded at the works
- can be installed at a minimum distance from the wall thanks to an angular flange

product example pr1mus easy line drain length 900 mm

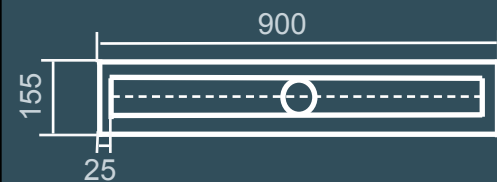

starting from
95 mm



starting from
120 mm



starting from
150 mm

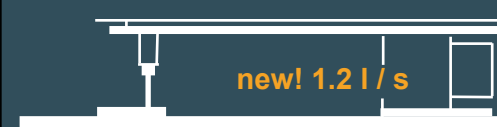

products

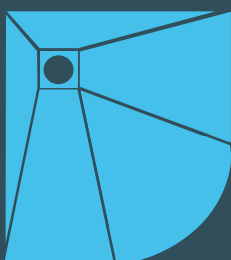
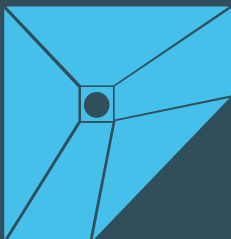
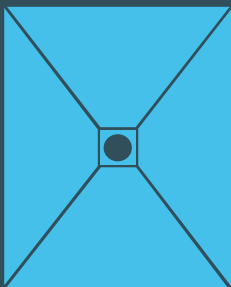
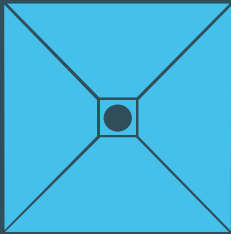

models & dimensions

shower board systems with concentrated drainage

pr1mus easy board and **pr1mus easy board flat** are available in many sizes and shapes

pr1mus easy board - standard formats with drainage - pr1mus easy board drain

central drainage

- 50 x 50 cm miniboard
- 80 x 80 cm
- 90 x 90 cm
- 100 x 80 cm
- 100 x 100 cm
- 120 x 90 cm
- 120 x 120 cm
- 150 x 150 cm

off-centre drainage

- 90 x 90 cm
- 100 x 100 cm
- 120 x 120 cm
- 180 x 90 cm

extremely high strength

- density approx. 100 kg / m³

pr1mus easy board - freesize with drainage - pr1mus easy board drain

pr1mus easy board offers almost unlimited structuring possibilities

individual designs are available in all sizes and shapes just contact us

density approx. 60 kg / m³

off-centre drainage

- < 1 m²: at least 20 cm from the board edge
- > 1 m²: at least 30 cm from the board edge

models & dimensions

shower board systems with concentrated drainage

pr1mus easy board flat with drainage - pr1mus easy board flat drain

- 90 x 90 cm
- 90 x 140 cm
- 100 x 100 cm
- 120 x 120 cm

shower board systems with line drainage

pr1mus easy board line with drainage pr1mus easy line drain 0.65 or 0.80 l/s

slope on one side

- 80 x 120 cm
- 90 x 90 cm
- 90 x 120 cm
- 100 x 100 cm
- 100 x 120 cm
- 120 x 120 cm
- freesize up to 120 x 120 cm
- freesize up to 150 x 150 cm

slope on four sides

- 90 x 90 cm
- 100 x 100 cm
- 120 x 120 cm
- freesize up to 120 x 120 cm
- freesize up to 150 x 150 cm

products

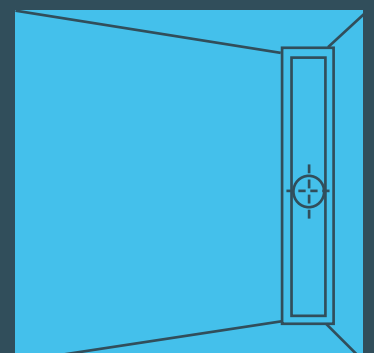
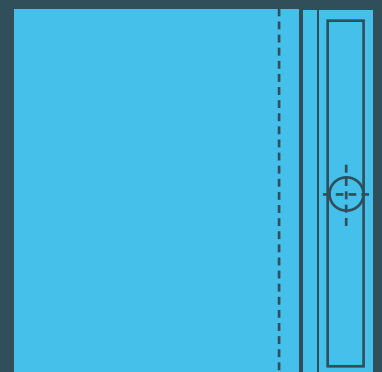
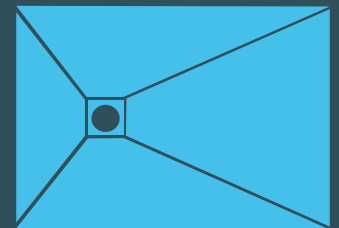
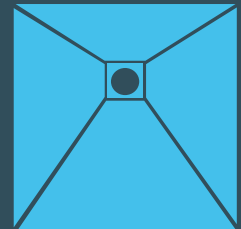



models & dimensions

line drainage systems

pr1mus easy line

with drainage pr1mus easy line drain 0.65, 0.8 or 1.2 l/s

design

as tile grate

as stainless steel grid in the designs

- design grid "sun"
- design grid "inka"
- design grid "smile"
- design grid "angle"
- design grid "basic"

drain lengths

with visual width of 73 mm, pr1mus easy line is available in the following drain lengths

- 700 mm
- 800 mm
- 900 mm
- 1000 mm
- 1200 mm
- 1500 mm

products

line drainage drain channel

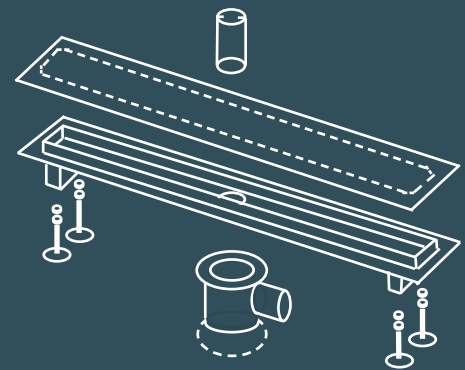

tile grate

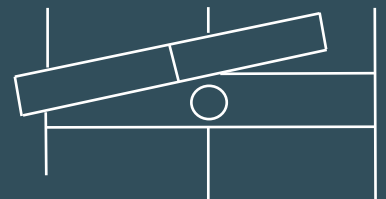

„sun“



„inka“



„smile“



„angle“



„basic“





reiner goss
managing director / ceo

intelligent, innovative solutions for construction, sealing and creative interior fittings, without barriers, but with value creation, know-how and first-class quality

this is what pr1mus is about

a short decision-making process combined with consistent action is what makes us who we are, and we always keep a watchful eye on the market

innovations are the basis of our success

we set trends
patented product solutions form a valuable contribution for our customers in their requirements of innovation, price consciousness and fully developed and reliable products

the people behind pr1mus

they are the most important asset of our company and the crucial factor for our success in the ever more dynamic markets

we work in an open, communicative atmosphere with flat hierarchies and room for creativity and individuality
the high level of commitment of every one of our employees has a single goal

our aim is to promote our customers` business with our ideas and thus enjoy fruitful partnerships

our international network of sales partners and companies operating worldwide ensures optimum communication and customer and market proximity on all continents

think global - act local

we work internationally and therefore know local markets
we develop and implement the ideas and requirements of our customers individually
behind each business deal - whether concerning global players or regional partners – there are people
these partnerships are held high in accordance with our philosophy

combining humanity and profitability

in doing so, our declared goals for the future are to go our – very own - way and to continue to internationally develop and strengthen our partnerships

the future is pr1mus!

we are there for you

as a specialist for fully-developed products and customised solutions we will gladly advise you in order to help you find the suitable solution for your individual requirements

if you have queries regarding our service or our products pertaining to the areas of:

showerPLAYces

- barrier-free construction

creative panels

- creative interior fittings

landscapes

- wellness products

sealing systems

- sealing membranes, tapes and system elements

subfloor systems

- subsonic noise insulation and isolation

floor protection

- protecting flooring

call us on

+ 49 (0) 26 32 / 49 98 - 0

or send us an email at

info@pr1mus.de

the future is pr1mus

we look forward to working with you!

primus[®]
bausysteme

gmbh
markt 19
d - 56626 andernach
tel.: + 49 (0) 26 32 / 49 98 - 0
fax: + 49 (0) 26 32 / 49 98 - 20
www.pr1mus.de
info@pr1mus.de

your **pr1mus**-partner near you

